

 12,4%



NATURAL
REFRIGERANT
R290

Key Features

The IM-100CNE-HC is a mid sized cube ice maker, which utilises Natural Refrigerant R290.

-  Energy efficient, with savings of 12,4% compared to HFC equivalent model.*
- ✓ Member of the Emerald Class, Hoshizaki's new range of climate friendly ice makers.
- ✓ Can produce up to 92 kg of cube ice per 24 hours (AT 10°C, WT 10°C).
- ✓ Unique ice making system that has an automatic rinse cycle. After every new batch of ice, the water reservoir drains and refills with fresh water.
- ✓ System comes with a magnetic water pump that has no direct coupling, which prevents any leakage.
- ✓ Closed water circuit offers the ultimate contamination protection, by reducing the number of points at which impurities can enter the ice making process.
- ✓ Electronically controlled to ensure an optimised ice making process under varying circumstances without the need for physical adjustments. Quality of ice is always consistent.
- ✓ Easily cleanable air filter allows end-users to carry out routine cleaning schedules. Extends product life expectancy and reduces the frequency and costs of maintenance call-outs.
- ✓ Stainless steel exterior with integrated door handles provides a hygienic and high quality finish.

* Based on Internal comparative study. Please contact your local sales branch to find out more.



IM-100CNE-HC-23
Ice: Cube (M)
Size: 28 x 28 x 23mm

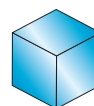

IM-100CNE-HC
Ice: Cube (L)
Size: 28 x 28 x 32mm

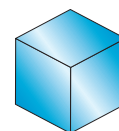

IM-100CNE-HC-32
Ice: Cube (XL)
Size: 32 x 32 x 32mm

Available Models

Model	Air Cooled	Water Cooled
IM-100CNE-HC	✓	
IM-100CNE-HC-23	✓	
IM-100CNE-HC-32	✓	

Bins

Model	Type of Bin	Max. Bin Capacity approx.
IM-100CNE-HC	Self-contained	38kg

Production

Model	Ice Production per 24h approx.	Temperature	Water Consumption per 24h approx.
IM-100CNE-HC	Approx. 92 kg (5mm)/105 kg (15mm)	AT 10°C, WT 10°C	0,47m ³
	Approx. 90 kg (5mm)/95 kg (15mm)	AT 21°C, WT 15°C	0,22m ³
	Approx. 75 kg (5mm)/84 kg (15mm)	AT 32°C, WT 21°C	0,18m ³

For more information visit our website at www.hoshizaki-europe.com

Hoshizaki Europe B.V. retains the right to change products and their specifications without prior notice.



IM-100CNE-HC

➔ CAD drawings available on our website

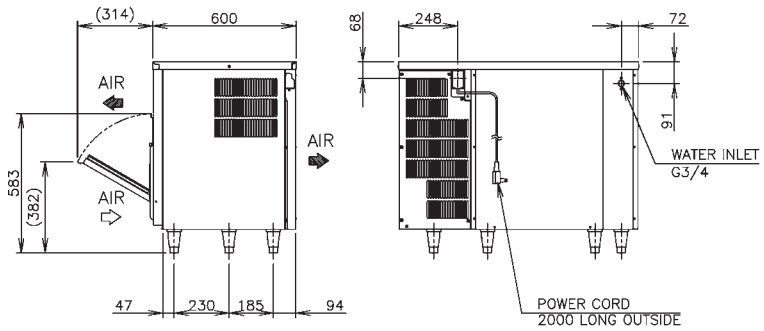
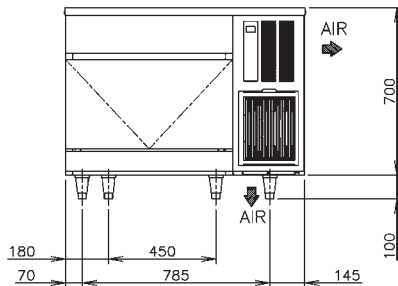
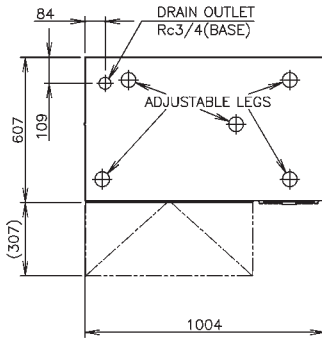

Specifications

	IM-100CNE-HC
Dimensions W x D x H (mm)	1004mm x 600mm x 800 (790-830)mm
AC Supply Voltage	1/220-240V 50Hz
Electric Consumption (AT 32°C, WT 21°C)	500W
Heat Rejection (AT 32°C, WT 21°C)	1150W
Refrigerant Charge	R290 / 125g
Isolation	Polyurethane
Weight Gross / Net	88kg / 77kg

Operation Requirements

Ambient Temperature	1 - 40°C
Water Supply Temperature	5 - 35°C
Water Supply Pressure	0,7-8bar (0,07-0.8MPa)
Voltage Range	Rated Voltage ± 6%

Accessories

Scoop
Installation Kit